

serie PV

**SPEEDS: 3****MOTOR:** M3 BL x 240W**MAX. FLOW. 200m³/h (5Pa):** 800 m³/h**MAX. PRESSURE:** 418 Pa**MIN. SOUND LEVEL:** 42 dB(A)**OUTFLOW:** 150 mm

Electronic panel VL3 with timer
Tableau électronique VL3 avec minuterie

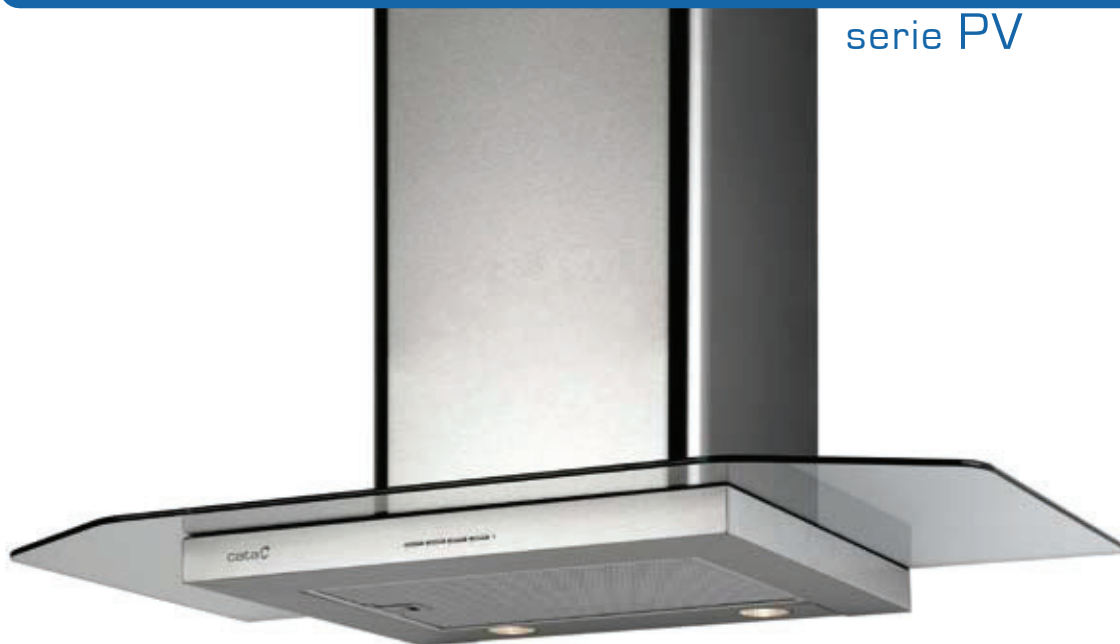

2 halogens x 50W
2 halogènes x 50W



Easy-to-clean reinforced interior
Blindage intérieur facilement nettoyable

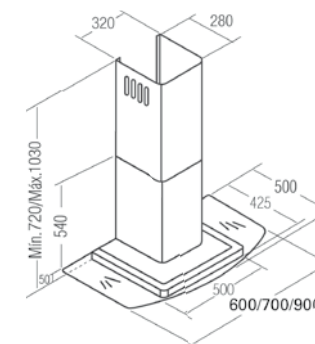

Sizes in mm
Dimensions en mm